

VAREC BIOGAS 247AT Series HIGH PRESSURE DRIP TRAP WITH ELECTRIC ACTUATOR

The 247AT Series High Pressure Drip Trap with Electric Actuator is designed for the automatic collection and safe removal of condensate from high pressure gas piping.

Introduction

Condensate removal from gas piping systems is necessary to protect piping and equipment from possible damage caused by corrosion or water hammer. In addition, water lying in low spots in piping can restrict gas flow resulting in increased pressure drop within the system. In addition to all low spots, Varec Biogas drip traps should be installed frequently along horizontal piping runs for convenient removal of accumulated condensate.

The 247AT Series Drip Trap is suitable for the automatic collection and safe removal of condensate from the gas and used for working pressures up to 100 psig (688 kPa). For systems with lower pressure ratings, see the product data sheet for Varec Biogas 246AT Series Low Pressure Drip Traps with Electric Actuators.

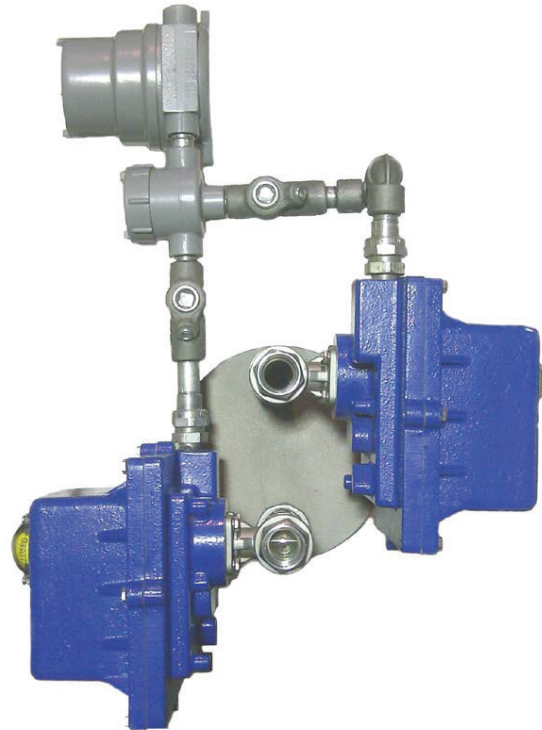

Operation

The Varec Biogas 247AT model consists of a high-pressure drip trap wherein the 'FILL' and 'DRAIN' ball plug valves are each individually controlled by interlocked electric rotary actuators.

Both actuators are directly mounted on the drip trap with epoxy painted steel bracket and stainless steel mounting hardware.

The unit is provided with a single timer enclosed in NEMA 7 housing to control the 'FILL' and 'DRAIN' sequence of the drip trap. The timer allows an operator the flexibility for automatic FILL and DRAIN cycles of the drip trap at a minimum of 35 minute intervals.

The timer is mounted on one actuator with a conduit seal which prevents passage of gases, and vapors and flames through the electrical conduit connection

Design Features

- Double - seal ball plug valves
- 100 psig (688 kPa) working pressure
- 4 Qt. Capacity reservoir
- All 316 SS

The low profile, dual chamber design (247D) can be provided with electric actuators to operate the ball valves on each chamber (247DAT). Consult ordering information and the factory for additional information.

Specifications

Connections

Inlet and Outlet 1" NPT Threaded

Maximum Working Pressure

100 psig (688 kPa)

Reservoir Sizes

4.0 Quart (3.8 L)

Low Profile, Dual Chamber Design

10 Quart per Chamber

15 Quart per Chamber

20 Quart per Chamber

Materials

All Stainless Steel

Low Profile, Dual Chamber Design

Carbon Steel Body

Epoxy Coated Internals (Standard)

Timer Enclosure

(When Specified Without a Control Panel)

NEMA 7, Aluminum

Control Panel

For added convenience, the electric actuator may come with a local control panel. The control panel can be supplied to control up to a maximum of three electrically actuated drip traps. The control panel also houses the cycle timer. The control panel will include the following for each drip trap controlled:

- a. Selector switch for 'Auto' or 'Hand' mode.
- b. Selector switch to open and close the drip trap while the drip trap is in the 'Hand' mode.
- c. Indicating lights to show if the drip trap is filling or draining.
- d. The control panel can be supplied in NEMA 4X (fiberglass or stainless steel construction). NEMA 4X panels is UL Approved.
- e. Consult factory if NEMA 7 (explosion proof), aluminum construction is required.

Consult factory for further information when specifying a local control panel.

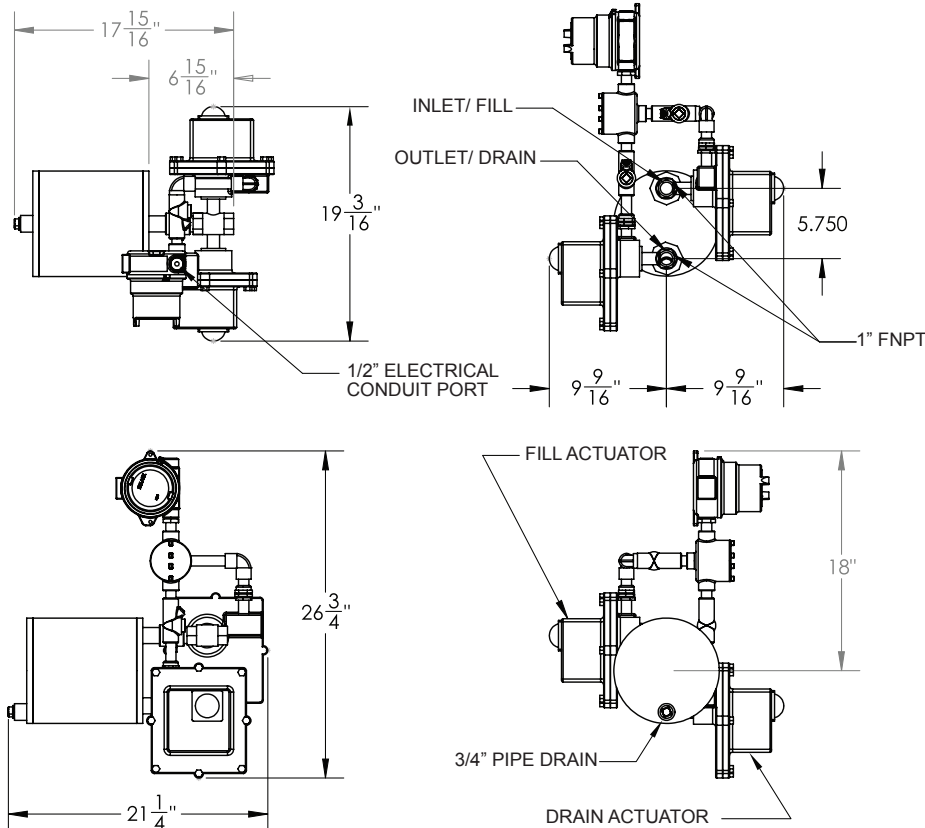

NOTE: Installation, mounting arrangement and dimensions are preliminary general information not be used for construction. Certified drawings are available.

Actuator Enclosure

Explosion Proof Rated for use in:

Class I, Division 1, Groups C & D

Class II, Division 1, Groups E, F & G

Weather Proof Option Available Upon Request

Performance Criteria

Speed

5 sec/ 90°

(25% Duty Cycle) 115 VAC or 200 VAC

Temperature Range

-40° F to +150° F (-40° C to +65° C)

Limit Switches

Provide for 0 to 90 degrees operation

Motor

High Torque, Reversible motor with Built-In Overload Protection

Actuator Voltage

120 VAC 50/60 Hz, Single-phase

220 VAC 50/60 Hz, Single-phase

Minimum Torque

300 in/ lbs (34 Nm)

Ordering Information

Model	Description			
247AT	High Pressure Electric Actuated Drip Trap			
	Code	Reservoir Size		
	4	4 Quart (3.8L)		
		Code	Material of Construction	
		S	All 316 SS (Standard)	
			Code	Options
			*	Leave Blank when specifying the timer mounted on the unit in its own NEMA 7 enclosure
			1	Actuator Attached Only, No Timer - Must have or purchased separate Control Panel ¹
247AT	4	S	*	(Example)

Example: 4 Quart High Pressure Drip Trap, All Stainless Steel Construction, with Actuator mounted in its own NEMA 7 enclosure.
NOTE: 1 - Consult Factory for further information when specifying a local Control Panel

Ordering Information

Model	Description			
247DAT	High Pressure Electric-Actuated Low Profile Dual Chamber Drip Trap, 100 psig Max Working Pressure			
	Code	Size		
	10C	10 Quart per Chamber Capacity Epoxy Coated Steel		
	10S	10 Quart per Chamber Capacity 316 SS		
	15C	15 Quart per Chamber Capacity Epoxy Coated Steel		
	15S	15 Quart per Chamber Capacity 316 SS		
	20C	20 Quart per Chamber Capacity Epoxy Coated Steel		
	20S	20 Quart per Chamber Capacity 316 SS		
		Code	Options	
		*	Actuator attached with Timer mounted in its own NEMA 7 enclosure	
		1	Actuator Attached Only, Must order separate Control Panel ¹	
247DAT	10S	*	(Example)	

Example: 10 Quart High Pressure Electric-Actuated Low Profile, Dual Chamber Drip Trap, All Stainless Steel Construction, with Actuator Mounted in its own NEMA 7 enclosure.
NOTE: 1 - Consult Factory for further information when specifying a local Control Panel.

Ordering Information - CONTROL PANEL

Model	Description			
247ATC	Drip Trap Control Panel			
	Code	Size		
	1	One		
	2	Two		
	3	Three		
	4	Four		
	5	Five		
		Code	Options	
		A	NEMA 4X Fiberglass	
		B	NEMA 4X 316 SS	
		C	NEMA 7 Aluminum (Maximum four drip traps per Control Panel)	
			Code	Options
			*	Leave Blank (None)
			1	Dry Alarm Contacts Provided
			2	Heater and Thermostat
			3	Dry Status Contacts
247ATC	3	B	123	(Example)

Example: Model 247ATC, Local Control Panel for 3 units, NEMA 4X 316 SS Construction with Dry Alarm Contacts, Heater, Thermostat and Dry Status Contacts.