

### VAREC BIOGAS 235 Series GAS PURIFIER

The 235 Series Gas Purifier is designed to be a cost effective system available to remove most  $H_2S$  from Biogas produced in anaerobic digesters, lagoons, and municipal landfills.

#### Introduction

Biogas is generated by the anaerobic digestion of organic solids that contain small amounts of hydrogen sulfide ( $H_2S$ ). It is produced in anaerobic digesters, lagoons, and municipal landfills.

Although the total percentage of  $H_2S$  in biogas is relatively small, it is often sufficient enough to corrode metals and damage equipment. This can create maintenance and operational problems especially in plants where the biogas is recovered to fuel engine-generators or boilers. In addition to corrosion problems,  $H_2S$  is a toxic air pollutant that can create a severe odor nuisance in minute concentrations. The treatment of biogas for removal of sulfur compounds has become increasingly important due to stringent regulations restricting sulfur emissions.



#### Applications

Biogas contains  $H_2S$  in concentrations from 500 to 3000 ppm or more, depending on the influent wastewater composition. The odor of hydrogen sulfide becomes offensive at 3 to 5 ppm. An atmospheric concentration of 300 ppm can be lethal. Even small amounts of hydrogen sulfide can cause piping corrosion, gas engine pitting, and piston ring clogging. Many engine manufacturers require the  $H_2S$  content to be as low as 100 ppm.

When biogas is burned or flared, the  $H_2S$  can generate sulfur dioxide ( $SO_2$ ) emissions.  $H_2S$  removal is a must when your local Regulatory Commission limits  $SO_2$  emissions. The 235 Series Purifier is designed to remove most of the  $H_2S$  from the biogas stream. It is usually installed upstream of a gas engine generator or boiler.

The following parameters should be measured for proper sizing and operation of the purifier:

Inlet biogas flow rate, inlet and outlet biogas pressures, inlet and outlet  $H_2S$  concentrations, condensation (drip water), pH of drip water, and estimated bed life.

Isolation valves (supplied by others) are recommended for field installation in the inlet and outlet piping of each compartment. Drip traps are recommended for installation in the drain connections of the purifier compartments to provide for safe condensate removal. It also provides the means to verify that the media is kept moist.

#### Operation

The 235 Series Gas Purifier utilizes a bed of iron sponge as the active media for  $H_2S$  removal. The sponge consists of wood shavings impregnated with a hydrated form of iron oxide ( $Fe_2O_3$ ). The wood shavings serve only as a carrier for the iron oxide powder. The sponge is loaded into the vessel, and is supported on wooden pine trays.

The vessel is divided into two tanks. Each compartment has inlet and outlet flange connections to allow digester gas to be scrubbed either in series or in parallel.

## Operation (Continued)

As the biogas goes through the compartment of the purifier and reacts with the media, the  $H_2S$  is removed by reacting with the  $(Fe_2O_3)$ . The chemical reaction results in forming ferric sulfide  $(Fe_2S_3)$ .

The chemical reaction is as follows:

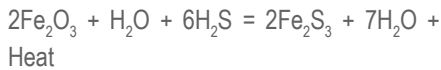

After some time, the sponge material is fully reacted. Exposing it to the atmosphere is one method of regenerating the iron sponge. Reaction of the spent sponge with atmospheric oxygen converts the  $Fe_2S_3$  to  $Fe_2O_3$ , and produces elemental sulfur. The regeneration reaction is exothermic and as long as the iron sponge is kept moist during the regeneration, the heat can only vaporize moisture and there is no danger of combustion.

The regeneration reaction is as follows:



Caking of the bed with the elemental sulfur limits the sponge life. When higher  $H_2S$  levels are measured on the outlet of the purifier beyond required levels, then the media can be regenerated or replaced.

### Manual Regeneration

Manual Regeneration is achieved by removing Iron Sponge from the vessel and exposing it to natural aeration. The sponge can be regenerated up to two times before it requires replacement. Each time the sponge is regenerated, it lasts up to 70% of its prior sponge life.

### Continuous Regeneration

The most economical method for long-term operation, maintenance cost and increased sponge efficiency is continuous or "On-Line" regeneration. In the Continuous Regeneration System, a controlled amount of air is injected into the gas at the purifier inlet (2.5% - 5% of total flow) to regenerate the media. A water spray wash system is in place for high-temperature safety control. A Soda Ash Slurry Injection System assists in maintaining pH balance. The "On-Line" regeneration system significantly extends the bed life of the media allowing minimal maintenance and operating cost.

## Design Features

- Specifically designed for low pressure biogas applications.
- Provides the necessary volume to ensure correct space velocity for efficient digester gas/iron sponge reaction time. Space velocity either too high or too low, may cause the biogas to channel or by-pass the iron sponge, resulting in inefficient  $H_2S$  removal.
- When installing more than one Purifier, the separate vessel's compartment can be operated in series or parallel. This provides the benefit of one vessel or each vessel's compartment being taken off line during maintenance while the other(s) are kept in operation.
- The Purifier can handle a finite range of operating conditions as defined in the specification section.
- Iron powder used to form the hydrated  $Fe_2O_3$  is manufactured specifically for this use which ensures its consistency. The wood carrier is especially selected for its impregnation and coating characteristics. The surface area is designed to provide maximum reaction with minimum pressure drop.
- The Purifier consists of a two compartment housing arranged for manifolding.
- Typical with manual regeneration, the two compartments are operated in series but for a short period of time, one compartment at a time can be taken off line for maintenance.

It is important to note that any variation to the original design conditions, along with variables such as moisture content and pH level will affect  $H_2S$  removal efficiency.

When the iron sponge is completely spent, it is generally disposed of in a sanitary landfill with a light earth cover.

Consult environmental agencies for local requirements.

### Sizing

Consult Factory for sizing. Please have the following information available:

- Flow Rate
- Inlet  $H_2S$  concentration in PPM
- Desired Outlet Concentration
- Indoor or Outdoor Installation

### Materials of Construction

Tank - Fabricated Steel (Option: Stainless Steel)

Cover Gaskets – Neoprene

### Support Requirements

A concrete foundation should be provided to support the purifier. Consult factory for clearance requirements.

### Paint Preparation

A. One shop coat of red oxide alkyd based primer applied to external surface (Standard).

B. Coal Tar Epoxy Coating on internal surfaces (Standard).

Consult factory for other special paint requirements.

Specifications

Dimensions, inches [mm]

Size Code	02	03	04	06	08	10
Size	2	3	4	6	8	10
<b>A</b>	42 [1067]	48 [1219]	60 [1524]	64 [1626]	74 [1880]	85 7/8 [2181]
<b>B</b>	36 1/2 [927]	33 [838]	49 3/4 [1264]	60 1/4 [1530]	67 [1702]	90 3/4 [2305]
<b>C</b>	56 1/4 [1429]	77 1/4 [1962]	84 1/4 [2140]	91 5/16 [2319]	119 3/8 [3032]	150 1/4 [3816]
<b>D</b>	32 [813]	38 [965]	48 [1219]	53 [1346]	59 7/8 [1521]	69 1/8 [1756]
<b>E</b>	28 1/8 [714]	38 5/8 [981]	43 1/4 [1099]	46 [1168]	59 7/8 [1521]	75 1/4 [1911]
<b>F</b>	10 [254]	10 [254]	12 1/4 [311]	12 [305]	15 1/8 [384]	17 3/4 [451]
<b>G</b>	18 1/8 [460]	28 5/8 [727]	31 [787]	34 [864]	44 3/4 [1137]	57 1/2 [1460]
<b>H</b>	3 1/8 [79]	6 [152]	6 [152]	6 [152]	8 [203]	10 [254]
<b>J</b>	50 [1270]	56 [1422]	68 [1712]	72 1/2 [1830]	82 1/8 [2086]	94 [2388]
<b>K</b>	5 [127]	5 [127]	5 [127]	5 [127]	7 3/8 [187]	8 3/4 [222]
<b>L</b>	5 [127]	5 [127]	5 [127]	5 [127]	6 3/4 [171]	8 [203]
<b>M</b>	2 [51]	2 [51]	2 1/2 [64]	2 1/2 [64]	3 [76]	3 [76]
<b>N</b>	5 [127]	5 [127]	5 [127]	6 1/4 [159]	7 3/8 [187]	8 3/4 [222]

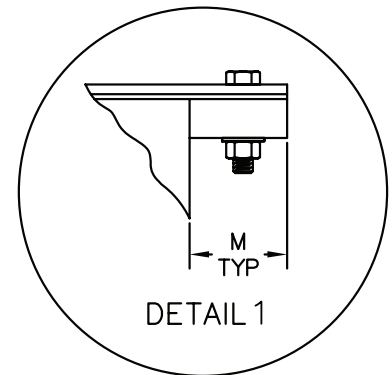
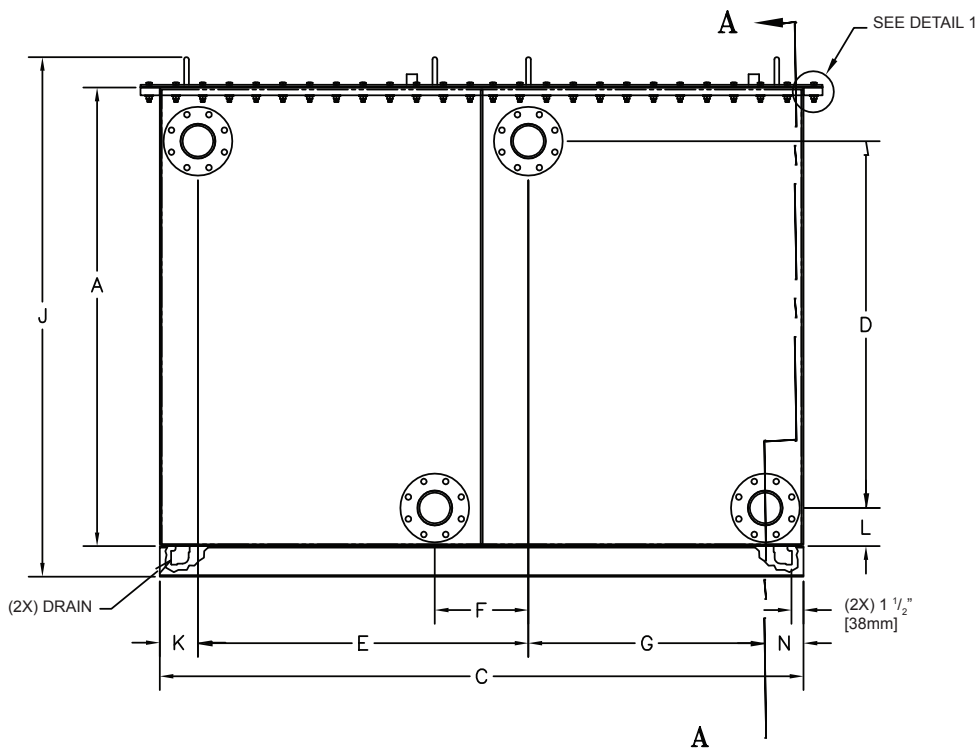
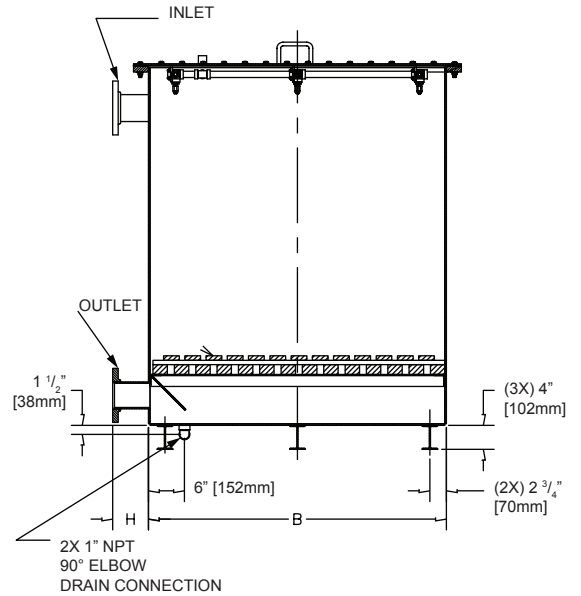

**Specifications**

**Configuration Options**

**STANDARD**

The unit will come equipped with thermometer on both components.

**STANDARD PURIFIER WITH AUTOMATIC WATER SPRAY SYSTEM**

The unit will come with thermocouple controlled Water Spray Wash System. Actuated by high temperature.

**CONTINUOUS REGENERATION SYSTEM**

The unit will come with a Water Spray Wash System, an Air Injection System and Soda Ash Injection System

**Optional Items**

**WATER SPRAY WASH SYSTEM**

A temperature switch is provided to continuously monitor the iron sponge bed temperature.

Explosion-proof solenoid valves are supplied to activate the water spray wash system.

Water is used to ensure proper moisture content in the media.

The water supply will automatically be activated if the temperature in the vessel reaches 120°F (49°C). This ensures that the sponge remains in a hydrated condition, and excess heat generated by the exothermic regeneration reaction is stabilized.

**SODAASH INJECTION SYSTEM**

To achieve the most efficient H<sub>2</sub>S removal operation the pH level of the system must not fall below 7.5 pH.

Soda ash is introduced into the system from a separate mixing tank to improve the pH level.

An explosion-proof sump pump and solenoid valves are provided to activate the soda ash injection system.

**AIR INJECTION SYSTEM**

NEMA 4X Fiberglass construction control panel housing the following components:

- An explosion-proof solenoid valve that will activate the air injection line.
- A pressure regulator that regulates constant air flow.
- An air flow meter to ensure that only 2.5% of the total flow rate is injected into the purifier.

**Ordering Information**

Model	Description	Code	Size	Code	Configuration	Code	Power Supply (If Required)
235	Waste Gas Purifier	02	2"	0	Standard (Includes Thermometer on Both Compartments)	0	Not Applicable
		03	3"	1	Standard Purifier with Water Spray Safety System	1	110/ 120 VAC, 50/ 60 Hz, Singel Phase
		04	4"	2	Continuous Regeneration System	2	220/ 240 VAC, 50/ 60 Hz, Single Phase
		06	6"				
		08	8"				
		10	10"				
235	04	0	0		(Example)		

Example: 235 Series Gas Purifier, 4" Size, Standard Configuration Including Thermometer, Power Supply Not Applicable